

Basic operation and functions

U15 series is single, dual and triple output DC/DC converters provide from 9.9 watts up to 15 watts of output power in an industry standard 2"x2" size package. The U15 series features 4:1 input voltage range, high efficiency, fixed switching frequency at 300KHz, continuous short circuit protection, six-side continuous shield and 500VDC isolation.

Input (Vi+ , Vi-)

Input power V_{in+} must be connected to Positive input voltage(+ V_{in}) ; Input power V_{in-} must be connected to Negative voltage(- V_{in}).

Output (Vo+ , Vo-)

Output power V_{out+} must be connected to Positive output voltage (+ V_{out}) ; Output power V_{out-} must be Negative output voltage (- V_{out}).

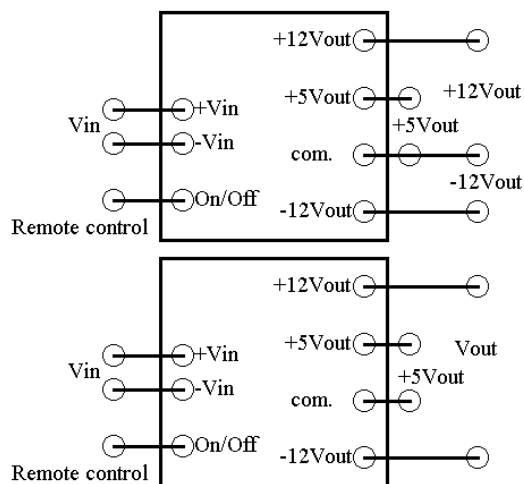

On / Off

The output allows the user to switch the module on and off electronically by remote on/off feature. This is only Positive logic remote control options available. The remote must use the CMOS or open collector TTL to control on/off pin.

Logic compatibility	CMOS or open collector TTL
Ec-on	>+5.5Vdc or open circuit
Ec-off	<1.8Vdc
Shutdown idle current	10mA
Control common	Referenced to input minus

Protection Features

Input under voltage lockout (UVLO)

The unit will shut down when the input voltage drops below a threshold, and the unit will turn on when the input voltage goes to the upper threshold.

The hysteresis voltage of the unit voltage protection is 1.0V(typ.), normally from the 7.5V to 8.5V range at input voltage is 24V.

Output over current protection (OCP) and output short protection

The unit will auto recovery current limit when the over current or short circuit condition exists.

Once the OCP happens, the unit has auto recovery current limit . The attempted restart will continue indefinitely until the over current or short circuit condition is removed.

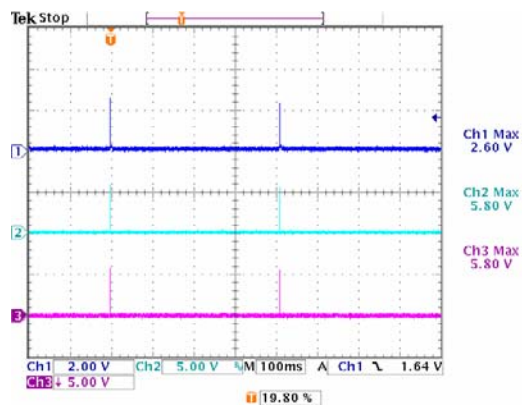

CH1:+5Vout/OCP Ch2:-12Vout/OCP
 CH3:-12Vout/OCP

- Servers, Switches and Data Storage
- Wireless Communications
- Distributed Power Architecture
- Semiconductor Test Equipment
- Networking Gear
- Data Communications
- Telecommunications
- Industrial / Medical

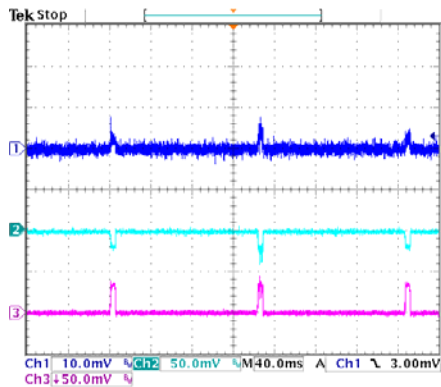

CH1: +5Vout/short CH2: -12Vout/short
 CH3: -12Vout/short

Characterization

General information

The U15 unit has many operational characterized aspects, including efficiency, start up, overshoot, output ripple & noise, dynamic response to load and input ripple current.

The following pages contain specific plots or waveforms associated with the unit. Additional comments for specific data are provided below.

Efficiency

Efficiency vs. load current is given below. The ambient temperature is 25C, airflow is 20LFM(0.1m/s), and the input voltage is 9V, 24V and 36V conditions.

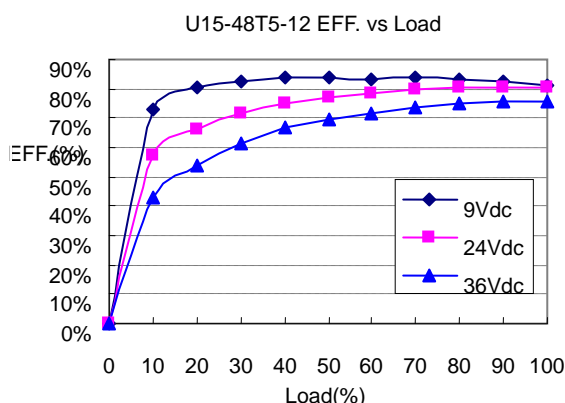

Start up

The input start-up from power supply.

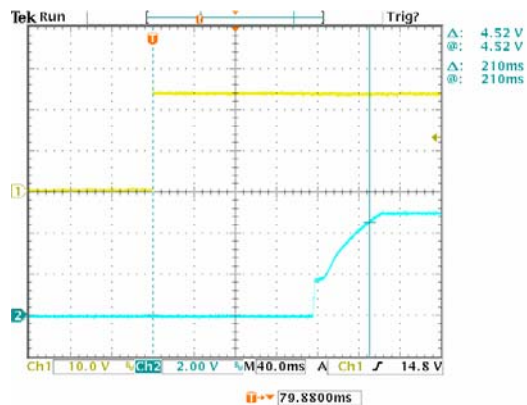

CH1: 24Vin CH2: 5Vout/FL

Start up delay time: 210ms

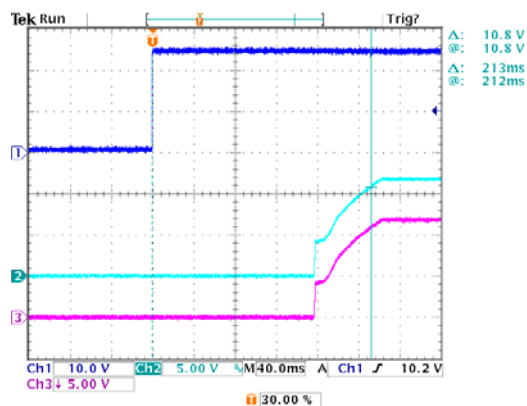

CH1: 24Vin CH2: +12Vout/FL

CH3: -12Vout/FL

Start up delay time: 213ms

The input start-up from remote on/off control and input voltage is 24V.

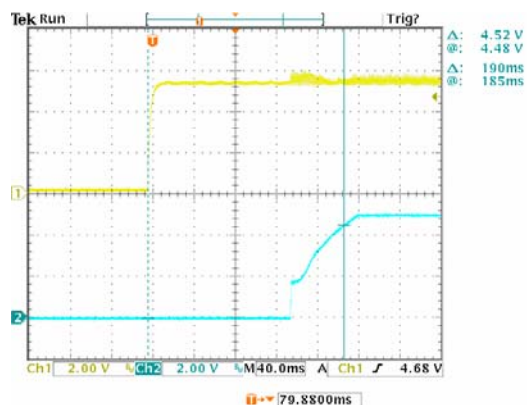

CH1: Remote CH2: 5Vout/FL

Start up delay time: 190ms

- Servers, Switches and Data Storage
- Wireless Communications
- Distributed Power Architecture
- Semiconductor Test Equipment
- Networking Gear
- Data Communications
- Telecommunications
- Industrial / Medical

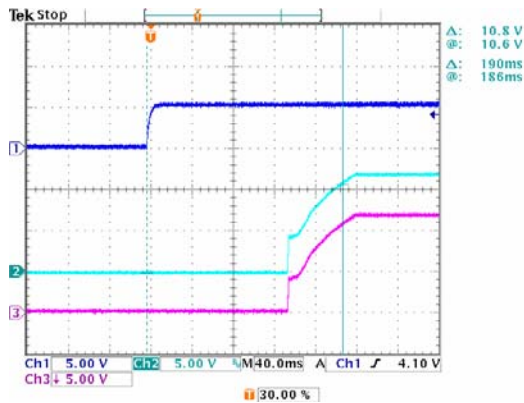

CH1: Remote CH2: +12Vout/FL
 CH3: -12Vout/FL

Start up delay time: 190ms

Output Ripple and Noise

The output voltage waveform measured at minimum load and full load current, with a 0.1uF ceramic capacitor across to close unit.

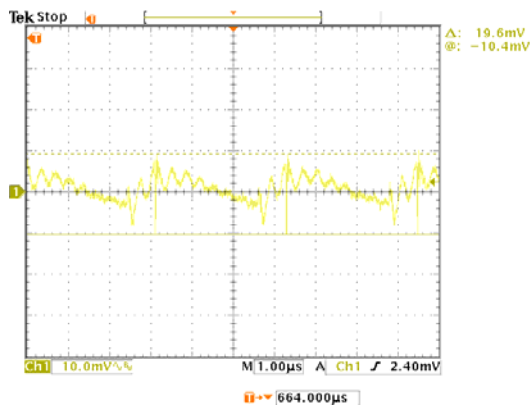

CH1: +5Vout/FL
 Ripple: 19.6mVp-p

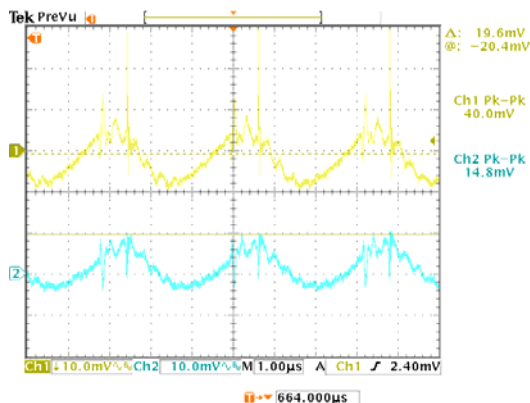

CH1: +12Vout/FL CH2: -12Vout/FL
 Ripple: 40.0mVp-p / 14.8mVp-p

Overshoot and rise time

The input start-up from power supply. The output voltage waveform measured at full load current.

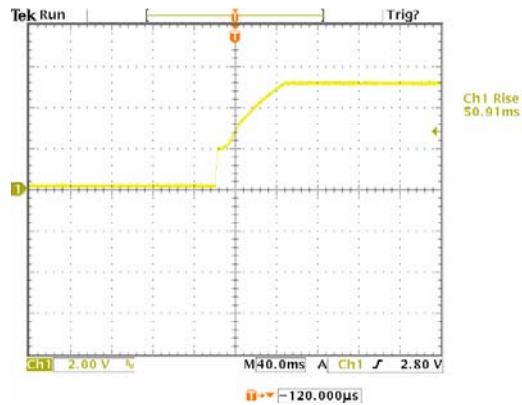

CH1: +5Vout/FL
 Overshoot: zero %
 Rise time: 50.91ms

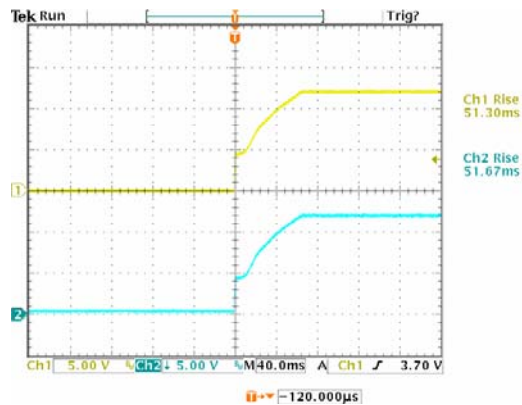

CH1: +12Vout/FL CH2: -12Vout/FL
 Overshoot: zero %
 Rise time: 51.30ms / 51.67ms

- Servers, Switches and Data Storage
- Wireless Communications
- Distributed Power Architecture
- Semiconductor Test Equipment
- Networking Gear
- Data Communications
- Telecommunications
- Industrial / Medical

Hold time

The hold time is measure from the power supply end to when Vout drop down to 90% output.

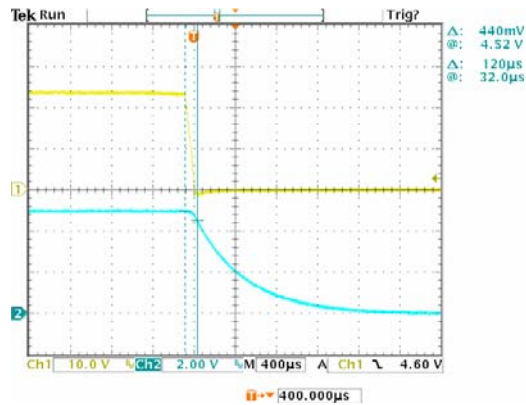

CH1: 24Vin Ch2: +5Vout/FL
 Hold time: 120us

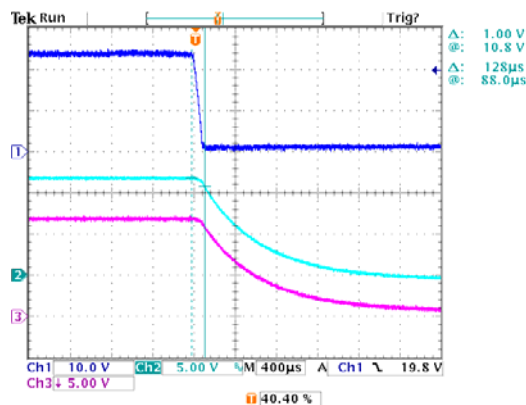

CH1: 24Vin CH2: +12Vout/FL
 CH3: -12Vout/FL
 Hold time: 128us

Dynamic response

Output voltage dynamic response at 24Vin and different load condition. Output with a 0.1uF ceramic capacitor.

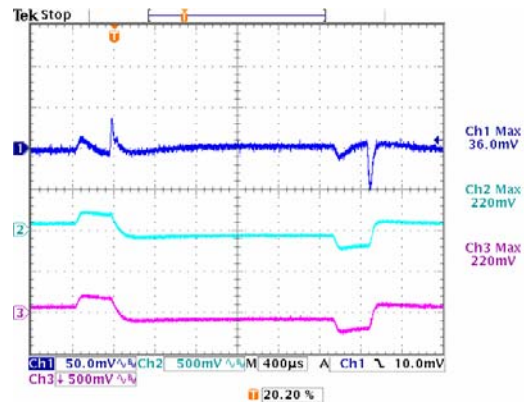

CH1: +5Vout Ch2: +12Vout
 CH3: -12Vout Iout: 0.1A/us
 Load change 50%-100%-50%

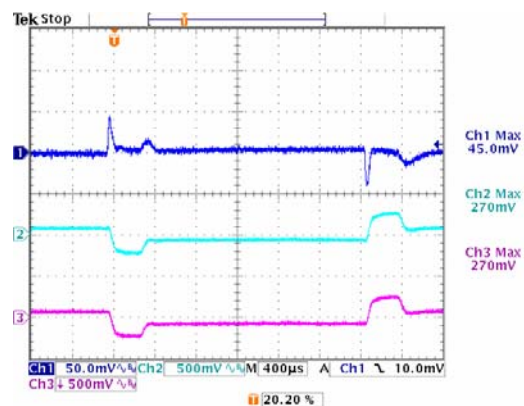

CH1: +5Vout Ch2: +12Vout
 CH3: -12Vout Iout: 0.1A/us
 Load change 25%-75%-25%

Input ripple current

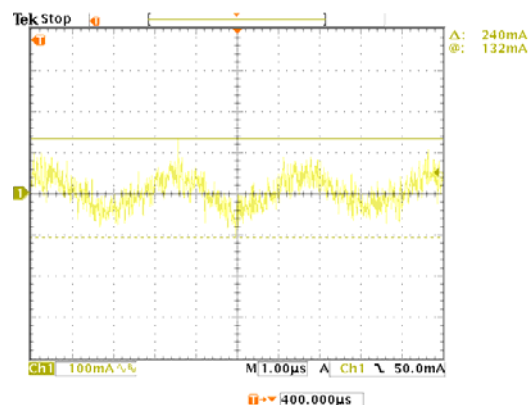

input ripple current: 240mA_{p-p}